

USN

--	--	--	--	--	--	--	--	--	--

10AU63

**Sixth Semester B.E. Degree Examination, July/August 2021**  
**Design of Machine Elements – II**

Time: 3 hrs.

Max. Marks:100

- Note: 1. Answer any FIVE full questions.**  
**2. Use of design data hand book is permitted.**  
**3. Missing data may be suitably assumed.**

- 1 a. List out the main differences between straight and curved beams. Also write the major assumptions made in finding stress distribution for curved beam. (08 Marks)  
b. Determine the dimensions of the C-frame of capacity 100 KN as shown in Fig. Q1 (b). The material of the frame is having maximum ultimate strength of 200 MPa and the FOS is 3. (12 Marks)

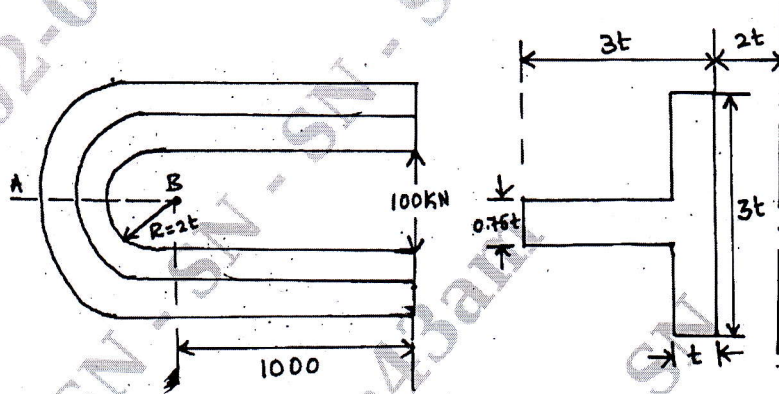

Fig.Q1 (b)

- 2 a. A high pressure cylinder consists of an inner cylinder of ID and OD of 150 mm and 200 mm respectively. It is shrink fitted by an outer cylinder of OD = 250 mm. Maximum tangential stress in the components due to shrink fitting is limited to 40 MPa. Determine the shrinkage pressure and stresses induced in cylinder due to shrinkage. Find the change in dimensions due to pressure. Also calculate necessary force required to disengage the joint having length of 200 mm. The material of the cylinder has modulus of elasticity  $2.10 \times 10^5$  MPa and Poisson ratio 0.3. Plot the resultant stress distribution. (15 Marks)  
b. A cylinder is provided with a head of flat circular steel plate of 500 mm dia and is supported around the edge. It is subjected to a uniform pressure of 5 N/mm<sup>2</sup>. The allowable working stress for the material is 70 N/mm<sup>2</sup> and Poisson ratio is 0.3. Determine thickness of cylinder wall and cylinder head. (05 Marks)
- 3 a. A single plate friction clutch running at 1000 rpm has to transmit power of 20 kW. There are two pair of frictional surfaces having a mean radius of 0.15 m. The axial pressure provided by six springs. If the springs are compressed by 0.005 m. Design the spring. Take  $C = 6$ ,  $\tau = 420$  MPa and  $\mu = 0.3$  (10 Marks)  
b. Design a leaf spring for the following specifications for a truck:  
Total load = 120 KN ; Number of springs = 4  
Material for the spring is chrome-Vandium steel.  
Permissible stress = 0.55 GPa ; Span of spring = 1100 mm  
Width of central band = 100 mm ; Allowable deflection = 80 mm  
Number of full length leaves = 2; Graduated leaves = 6. (10 Marks)

Important Note : 1. On completing your answers, compulsorily draw diagonal cross lines on the remaining blank pages.  
2. Any revealing of identification, appeal to evaluator and /or equations written eg. 42+8 = 50, will be treated as malpractice.



- 4 a. In a multiplate clutch the radial width of the friction material is to be 0.2 of maximum radius. The coefficient of friction is 0.25. The clutch is to transmit 60 kW at 3000 rpm. Its maximum diameter is 250 mm and axial force is limited to 600 N. Determine:  
(i) Number of driving and driven discs. (ii) Mean unit pressure on each contact surface.  
Assume uniform wear. (10 Marks)
- b. A simple band brake of drum diameter 600 mm has a band passing over it with an angle of contact of  $225^\circ$ , while one end is connected to the fulcrum, the other end is connected to the brake lever at a distance of 400 mm from fulcrum. The brake lever is 1 m long. The brake is to absorb a power of 15 KW at 720 rpm. Design the brake lever of rectangular cross section. Assume depth to be thrice the width. Take allowable stress is 80 MPa and  $\mu = 0.3$  (10 Marks)
- 5 a. Derive the Lewis equation for the beam strength of a Spur gear tooth. Also list the assumptions. (05 Marks)
- b. Design a pair of helical gear to transmit 12 kW at 2400 rpm of pinion. The velocity ratio required is 4 : 1, Helix angle is  $23^\circ$ , the centre distance is to be around 300 mm. Pressure angle in the normal plane is  $14\frac{1}{2}^\circ$  involute. Pinion material is cast steel ( $\sigma_{01} = 51.7$  MPa), gear material is CI ( $\sigma_{02} = 31$  MPa). The form factor may be taken as  $0.124 - \frac{0.684}{Z_v}$  where  $Z_v$  is the equivalent number of teeth. The velocity factor may be taken as  $\frac{6}{6 + V_m}$  where  $V_m$  is pitch line velocity in m/sec. (15 Marks)
- 6 A pair of straight bevel gear transmit 15 kW. Determine the required module, face width and number of teeth on pinion and gear. Suggest suitable hardness if the wear strength has to be more than the dynamic load.

Particulars	Pinion	Gear
Material	Alloy steel case hardened (SAE2320)	Case Steel 0.20% C heat treated
Speed	1250 rpm	357 rpm
Number of teeth	20	70
Allowable static stress	345 N/mm <sup>2</sup>	173 N/mm <sup>2</sup>
Diameter	120 mm	-

(20 Marks)

- 7 a. Explain the following:  
(i) Hydrodynamic theory of lubrication (ii) Sommerfield number.  
(iii) Bearing characteristic number. (06 Marks)
- b. A hydrodynamic journal bearing of diameter 75 mm and length 75 mm uses a oil of SAE 20 of absolute viscosity 32 CP. When oil enters at  $40^\circ\text{C}$  the journal rotates at 1200 rpm. The diametral clearance is 75  $\mu\text{m}$  (0.075 mm). Assume operating temperature of the oil as  $53^\circ\text{C}$ . Determine ; (i) Magnitude and location of the minimum film thickness. (ii) Power loss. (iii) Oil flow through bearing. (iv) Side leakage. (14 Marks)
- 8 a. Derive the equation  $\frac{T_1}{T_2} = e^{\mu\theta}$ , where  $T_1$  is tension in the tight side,  $T_2$  = Tension in slack side,  $\mu$  = coefficient of friction between belt and pulley,  $\theta$  = Angle of contact. (05 Marks)
- b. A roller chain is to transmit 66.24 KW from a 17 tooth sprocket to a 34 tooth sprocket at pinion speed of 300 rpm. The load are moderate shock. The equipment is to run 18 hr/day. Specify the length and size of the chain required for a centre distance of about 25 pitches. (15 Marks)

\* \* \* \* \*